

# AIRTECT

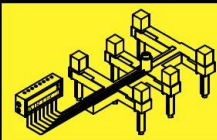

Plastic Leak Alarm System

## FOCUS ON PREVENTION

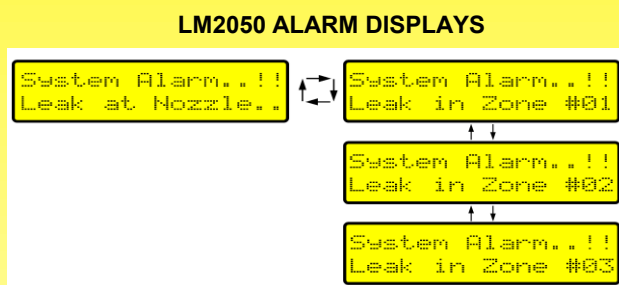
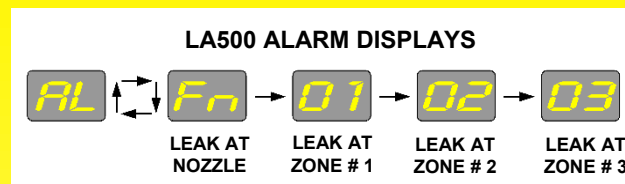
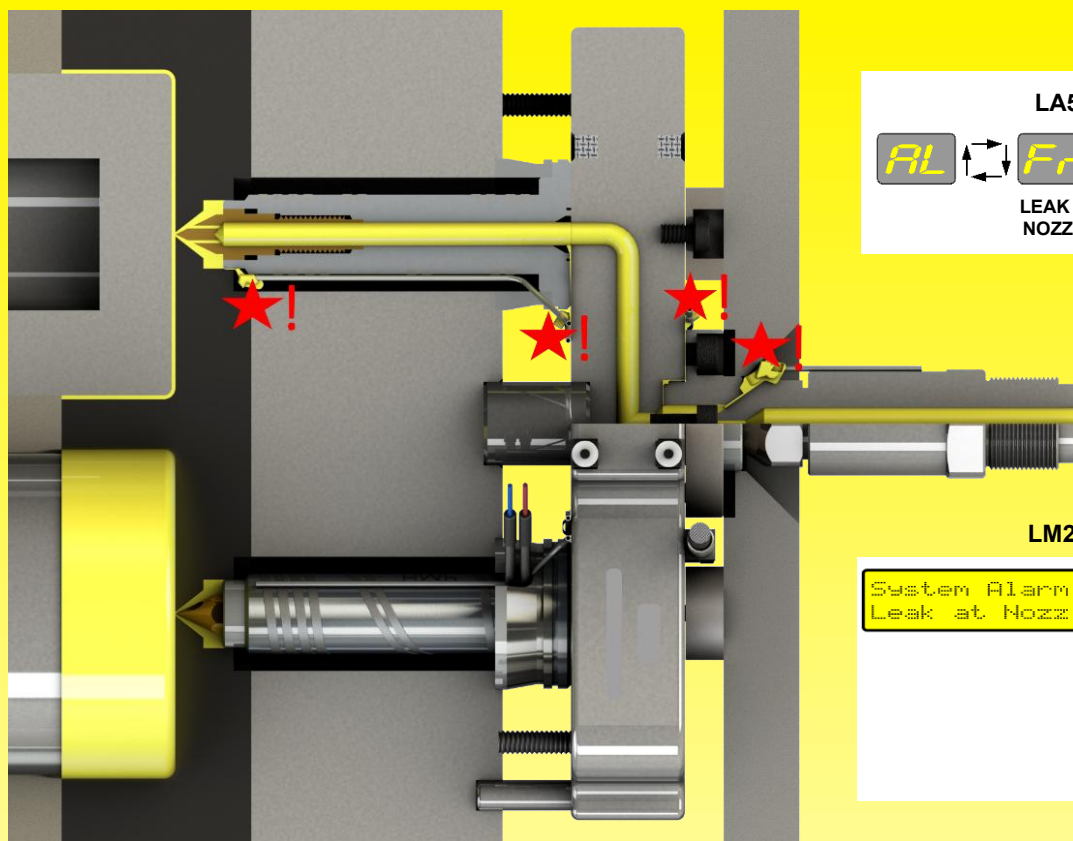
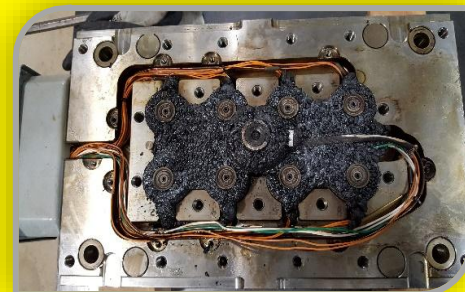
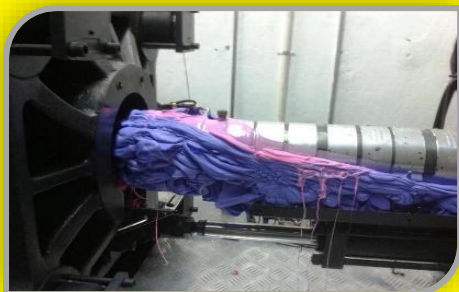

- Reduce the problem of Plastic Leak Damage at the IMM Injection Nozzle or inside a Hot Runner System with an AIRTECT Plastic Leak Detection Solution.
- AIRTECT Plastic Leak Detection Solutions are being mandated worldwide by many companies especially in Automotive, Packaging and Medical Device manufacturing.
- AIRTECT Plastic Leak Detection Solutions are supplied worldwide by a network of distributors.

## Plastic Leak Detection Solutions

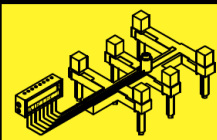

### Full range of NOZZLE and HOT RUNNER Leak Detection Modules



#### NOZZLE AND BARREL PROTECTION

#### 'NOZZLE' LEAK DETECTION MODULES LA500, LA502 and LM2050

Work as Single or Dual (2K) IMM Nozzle Leak Detectors  
+ Control/Display/Relay Interlock Modules for  
'STANDARD' and 'MODULAR' Leak Detection Manifolds

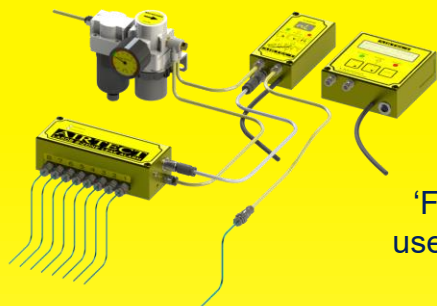

#### NOZZLE and HOT RUNNER MOULD PROTECTION

#### 'FIXED' and 'MODULAR' LEAK DETECTION MANIFOLDS

'FIXED' and 'MODULAR' Multi-Zone Leak Detection Manifolds are  
used with either an LA500, LA502 or LM2050 Control/Display / Relay  
Interlock Module

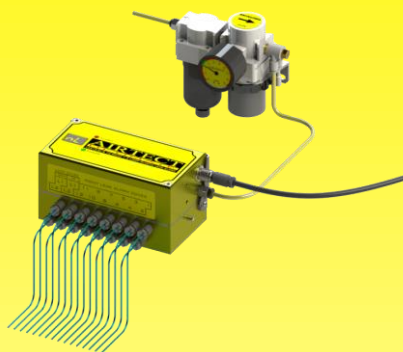

#### HOT RUNNER MOULD PROTECTION

#### 'FIXED' and 'MODULAR' STAND- ALONE LEAK DETECTION MANIFOLDS

'STAND-ALONE' Multi-Zone Leak Detection Manifolds have an  
integral Control/Display / Relay Interlock Module

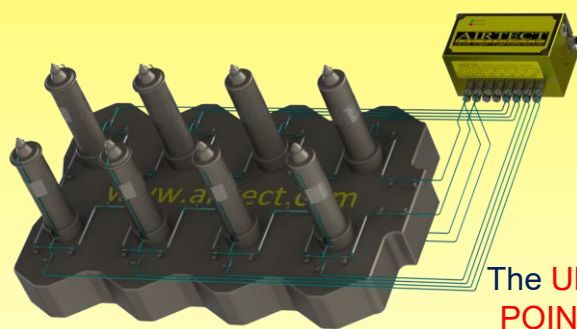

#### HOT RUNNER MOULD PROTECTION

#### 'ULTIMATE' 'FIXED' and 'MODULAR' STAND-ALONE LEAK DETECTION MANIFOLDS

The **ULTIMATE** range of Leak Detection Manifolds have both  
**POINT** and **CLOSED LOOP** Leak Detection Zones and are  
available as 'Stand-Along' units only.

## Detect Your NOZZLE and HOT RUNNER Leaks Early!

DESIGNED AND MANUFACTURED BY:

GKET Ltd., E5 Swords Enterprise Park, Feltrim Road,  
Swords, Co. Dublin. IRELAND  
info@airtect.com www.airtect.com

REPRESENTED BY:

see [www.airtect.com/distributors](http://www.airtect.com/distributors)